

OWNER'S MANUAL

Absolutely State of the Art Mobile



TABLE OF CONTENTS

Congratulations	2
Service	2
Caution	2
Features	3
QBASS PLUS Specifications	3
Specifications	4
Amplifier Status LEDs	6
Tools/Parts for Installation	7
Wiring	7
Ground Wiring	9
Charging System	9
Current Draw	10
Power Wire Size	11
PowerLock Connectors	12
DCX-500.1, 1000.1, 1500.1 Front Plate Diagrams	13
DCX-500.1, 1000.1, 1500.1 End Plate Diagrams	14
Inputs	15
Advanced Instrumentation Input	16
QBASS PLUS/QBASS Remote	17
TC-X Crossover	18
Crossover Detent Chart	19
Adjusting Input Gain	20
High Mass Internal Heatsink	20
AP-IV Protection Circuit	20
Troubleshooting	20

CONGRATULATIONS

Thank you for choosing *PrecisionPower™* audio equipment. Designed and engineered in the USA, this product combines innovative technology with the finest materials to consistently deliver *Absolutely State of the Art™* performance, sound quality, reliability, and value. This *PrecisionPower™* product reflects our commitment to offer you unparalleled performance and quality for years of dependable service and listening enjoyment.

SERVICE

Do not attempt to service *PrecisionPower™* products yourself. Performing maintenance on your audio equipment will void the warranty. Many parts of the *PrecisionPower™* product are custom built to our specifications. **Our factory parts are not made available to anyone else nor are they for sale.** Our goal is to make sure that your *PrecisionPower™* product will always sound asJ -1

FEATURES

New! Advanced Instrumentation Input Stage.

New! 24dB/Octave; HP/LP/FULL; 30-4kHz Crossover.

New! Independent Line Output Crossover 30-4kHz

PWM Power Supply

Triple Darlington Output Stage.

AP-IV Protection Circuitry

QBASS™ Bass Boost

High Voltage Input Capability with -12dB Attention Switch.

Gold Plated RCA Input and Output Connectors.

PowerLock™ Speaker and Power Wire Connectors.

2 Yr Warranty; if installed by an Authorized *PrecisionPower* Dealer.

QBASS PLUS SPECIFICATIONS

QBASS PLUS™

Up to 18dB of boost with selectable center frequency at 30Hz, 36Hz, 44Hz or 60Hz, with a Q-factor of 2.

Optional **QBASS REMOTE™**

This boost control can be mounted in the dash and will supersede the boost control on the amplifier endplate.



SPECIFICATIONS

Power Ratings

<u>MODEL</u>	<u>4ohm MONO</u>	<u>2ohm MONO</u>	<u>1ohm MONO</u>
DCX 500.1	1 X 200	1 X 300	1 X 500
DCX 1000.1	1 X 400	1 X 600	1 X 1000
DCX 1500.1	1 X 500	1 X 1000	1 X 1500

All power ratings given above are tested at 12.5V; 4 ohms; 20Hz - 200Hz.

General Specifications

Conversion Efficiency	>80% @4 ohms
Frequency Response	20Hz - 200Hz +0, -1dB
Total Harmonic Distortion	<0.02%
S/N Ratio	>80dB
Input Sensitivity	200mv - 5 Volts RMS
Phase Adjust	0–180°, selectable switch
RCA Output Jacks	HP/LP/Full; 30Hz to 4kHz
Input Impedance	40,000 Ohms
Supply Voltage	9 - 16 Volts
Damping Factor	>50
Slew Rate	>50V/μs
<i>QBASS PLUS™</i>	Up to +18dB Boost @30, 36, 44, or 60Hz
Crossovers Type/Range	LP—30Hz to 250Hz HP—off/24dB switch 20Hz to 100Hz LP—off/24dB switch 30Hz to 250Hz
Protection Functions	Short, thermal, over voltage (16V) and under voltage (9V)

Fuse Requirements

You will need to install an in-line fuse or circuit breaker in the power wire within 18" of the battery. This fuse or circuit breaker is to protect your vehicle from fire in case the power wire shorts to the vehicle body. If you are only using one amplifier, use the fuse rating indicated in this chart. If you are using more than one amplifier, add up the fuse ratings for all the amplifiers. This sum is the rating for your fuse or circuit breaker. You may also want to add a power distribution block near your amplifiers to distribute large gauge power cable to multiple amplifiers.

Amp	Fuse
DCX 500.1	50 A
DCX 1000.1	100 A
DCX 1500.1	150 A

Dimensions

	Length	Width	Height
DCX 500.1	21- $\frac{1}{2}$ "	10- $\frac{1}{2}$ "	2- $\frac{3}{4}$ "
DCX 1000.1	24- $\frac{3}{4}$ "	10- $\frac{1}{2}$ "	2- $\frac{3}{4}$ "
DCX 1500.1	29- $\frac{3}{8}$ "	10- $\frac{1}{2}$ "	2- $\frac{3}{4}$ "

AMPLIFIER STATUS LEDS

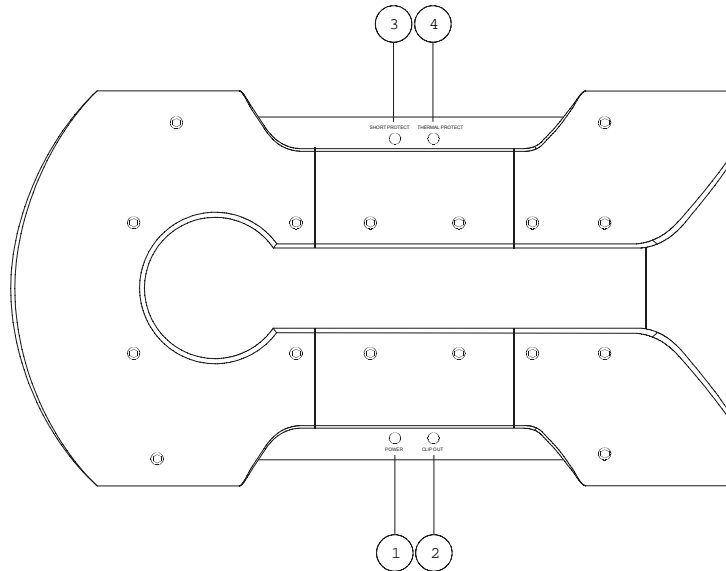

The LEDs provide the following indications:

- 1. Power** - This LED illuminates RED when the amplifier power is turned on with the remote input (output muted). After a short time delay this LED will turn GREEN (amplifier ready).
- 2. Clip Output** - This LED illuminates RED on the peaks of the output signal when the peaks are too high. This clipping causes audible distortion in the speakers.
- 3. Short** - This LED illuminates RED on a short condition. The amplifier will turn off and try to turn back on.
- 4. Thermal** - This LED illuminates RED on a thermal condition. The amplifier will turn off and turn back on in a minute or so.

Note: Read the **AP-IV Protection Circuit** section for additional information regarding **Short and Thermal** protection.

TOOLS/PARTS FOR INSTALLATION

NOTE: TOOLS ARE NOT SUPPLIED.

Small flat blade screwdriver

Phillips screwdriver (#2 or medium sized)

Wire cutters

Wire strippers

4 - #6 round head screws, and 1 - #8 sheet metal screw. (or nut, bolt, flat washer, star washer) (see details)

2 - Ring connectors (large enough to accommodate your method of grounding)

In-line fuse or circuit breaker

Power and ground wire

Speaker wire - 12-16 gauge

Grommets (sized to work with the power wire you plan to use in your installation)

Tube of silicone sealant

WIRING

Before beginning, disconnect the negative (-) terminal of the battery prior to connecting the amplifier to the positive (+) 12V terminal to prevent a short to ground and potential damage to wiring and equipment. Some vehicle radios have an anti-theft feature where when the radio is removed from 12V the radio will no longer function and must be code reset.

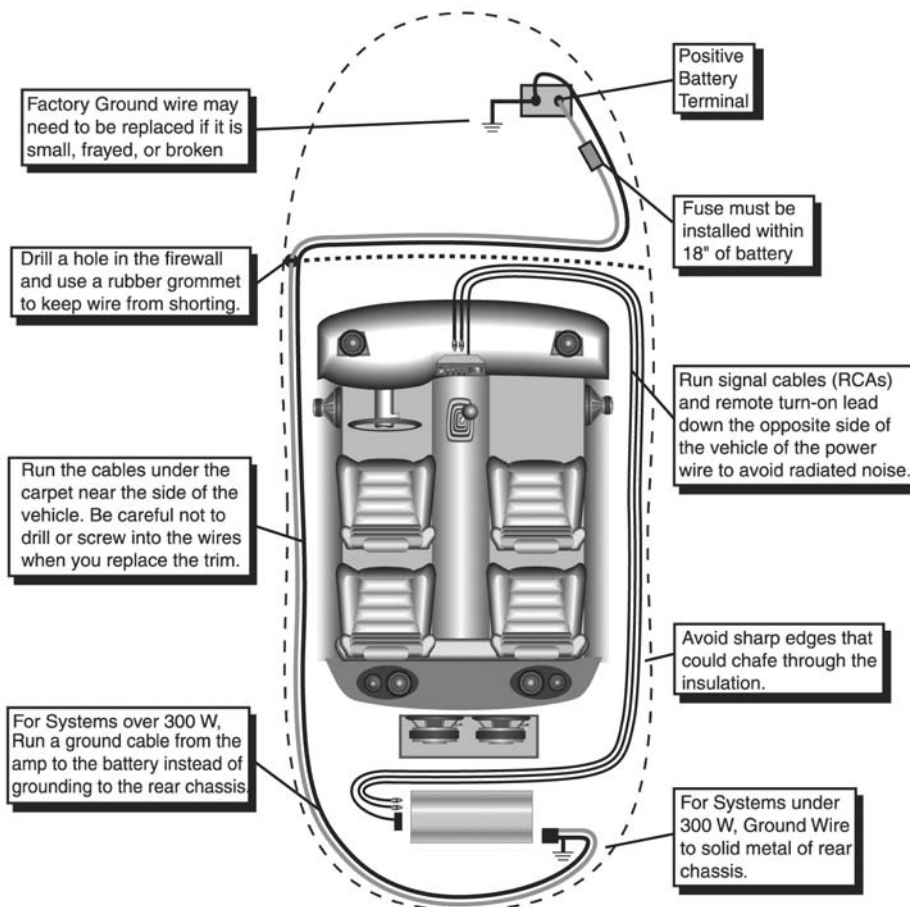

Note: The cables running from the battery to the rear of the car should be installed on the side of the car opposite to the antenna.

When using 16 gauge wire or larger, run the speaker wires from the amplifier location through the vehicle to the speakers. Observe the same precautions for routing these wires that you followed for running the power and remote turn on wires. Cut off excess and, using wire strippers, strip 1/4-inch of insulation. Locate the speaker/remote turn-on **PowerLock™** connector. Loosen the outer screws on the underside of the connector. Insert the speaker leads into the end. Check to be sure you've maintained proper polarity before securing each wire, and plug the **PowerLock™** into the amplifier.

Note: The power connector is inserted into the amplifier with the wire clamping screws in the up position as shown below. The two negative outputs are common to each other as the two positive outputs. A speaker may be connected to either terminal.

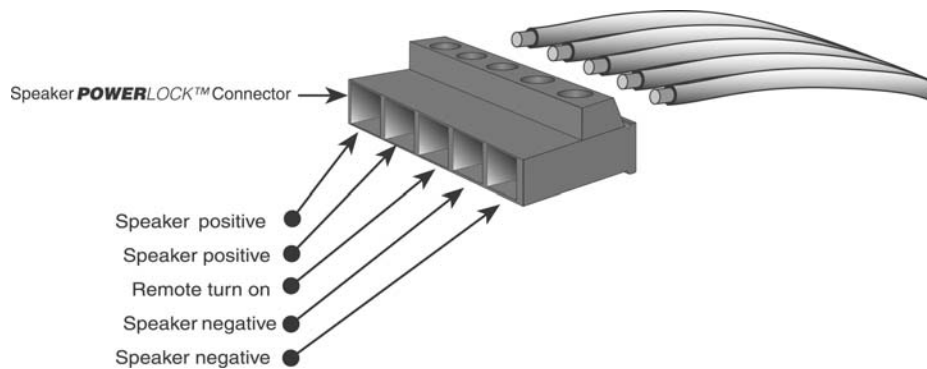

GROUND WIRING

Locate an area near the amplifier(s) that is metal and clean an area about the size of a quarter down to bare metal. Inspect the area around and underneath to be sure you will not drill into wires, brake or fuel lines, etc. Drill a pilot hole in the middle of this area. Terminate the ground wire with a ring connector and attach it to the bare metal using a #8 sheet metal screw and washer or preferable, a bolt, nut and a star washer. (not supplied). We suggest crimping and soldering this connection. After the connection is complete, coat the area (on both sides) with silicone or some similar material to prevent rust from

developing on the bare metal. If your total current draw is over 80 amps (*or total power is over 500 watts*). Keep the ground and power wires as close together as possible, and use the same gauge wire for both. This will ensure that you have a good ground path, and may eliminate such potential problems as engine noise and overheated amplifiers.

CHARGING SYSTEM

If your total current draw is over 100 amps (*or total output power is*

over 600 watts), you are probably exceeding the capability of your charging system. Dimming lights and fluctuating voltage are solid indicators that you need to upgrade your alternator, battery, or both. You should also check the condition and current capacity of the stock battery negative cable and connections, and replace or upgrade as necessary. Keep in mind that your amplifiers simply convert electrical energy to acoustical energy, and any electrical deficiency will compromise the performance of your sound system. For more information about charging system upgrades, see you local authorized *PrecisionPower™* Dealer or call *PrecisionPower™* Technical Support at **1-800-62POWER x2033**.

CURRENT DRAW

The following is a basic formula to be used as a guide to determine current draw. Your new **DCX** amplifier is more efficient than most other amplifiers. This formula is to be used as a guideline. Using wire of a larger gauge can only improve the current transfer of your system. Do **NOT** use smaller wire gauge.

$$\text{Total RMS output} \times 1.5 = \text{Total Input Wattage}$$

$$\frac{\text{Total Input Wattage}}{\text{Supply Voltage}} = \text{Current Draw (in Amps)}$$

Example: A **DCX** amplifier has two channels at 125 watts per channel RMS rating into 4 ohms (125X2 = 250 watts).

You would use the formula in the following way:

$$500 \text{ W} \times 1.5 = 750 \text{ watts}$$

$$\frac{750\text{W}}{12\text{V}} = 62.5 \text{ Amps total current draw}$$

If the same amplifier is driven into a 2 ohm stereo or 4 ohm mono load, double it's 4 ohm RMS rating. All **DCX** amplifiers will effectively double their power at this load.

$$500W \times 1.5 \times 2 = 1500 \text{ watts}$$

$$\frac{1500W}{12V} = 125 \text{ Amps total current draw}$$

If you are using more than one amplifier, add up the total current draw for all of them and choose the appropriate gauge based on the grand total.

POWER WIRE SIZE

A minimum of 8 gauge or a maximum of 4 gauge wire is recommended dependent on the application.

The ground wire must be the same gauge as the power wire.

POWERLOCK CONNECTORS

Once you have run both the power and ground wires, then connect the cables to the amplifier. Cut off excess wire, and using wire strippers, strip the ends of the power and ground cables approximately 1/4 inch. Locate the *PowerLock™* power and ground connector (supplied). With a small flat blade screwdriver, loosen the screws before attempting to insert the cable wires. Insert the wires into the appropriate hole, and tighten the screws. Once the wires are secure, the *PowerLock™* may be plugged into the amplifier. The Power/Ground *PowerLock™* will accommodate 4 gauge wire for the ***DCX 500.1***, ***DCX 1000.1*** and ***DCX 1500.1***.

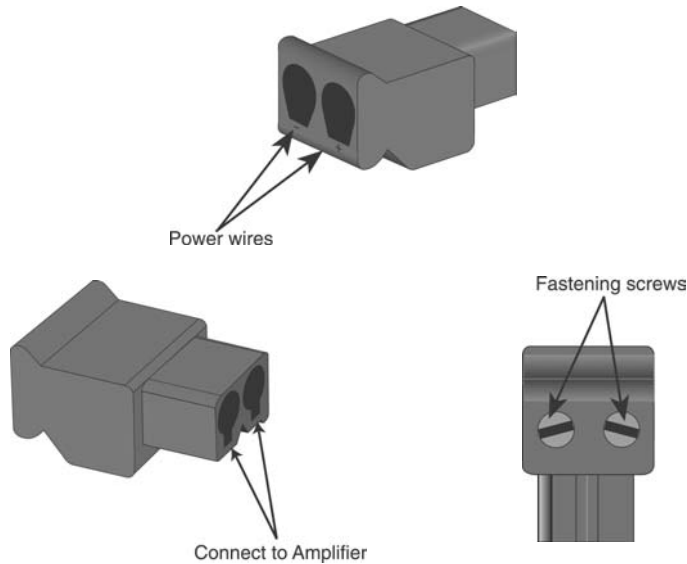

DCX-500.1, 1000.1, 1500.1 FRONT PLATE DIAGRAMS

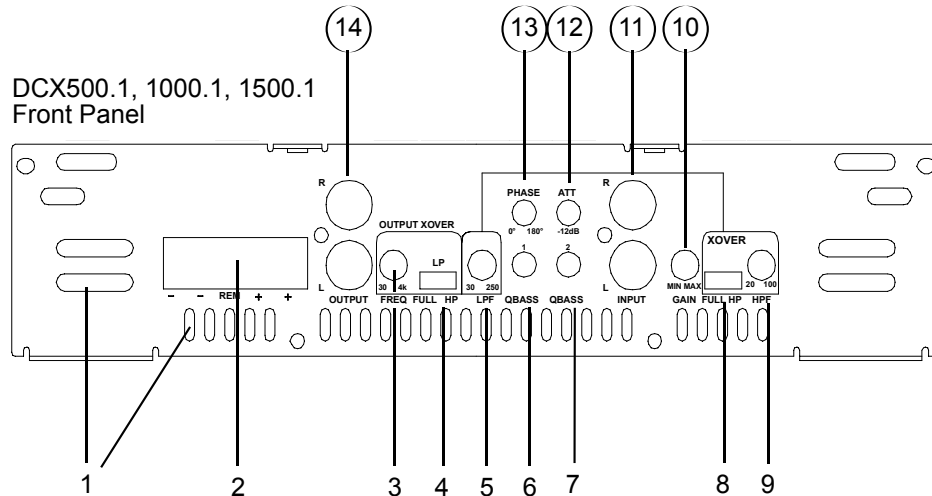

- 1. Cooling Plenums:** Maintain a minimum 2" clearance around cooling plenums for proper amplifier cooling.
- 2. Speaker/Remote Connector:** Plug in the *PowerLock™* connector here.
- 3. Output Freq. Control:** Use this control to adjust the sub bass output signal crossover frequency from 30Hz to 4kHz. (See the Crossover Frequency chart in this manual).
- 4. Output HP/LP/FULL Switch:** Select the desired crossover setting HP/LP/FULL for the signal of the RCA outputs.
- 5. LPF Level Control:** Allows adjustment of the LPF between 30Hz and 250Hz.
- 6 & 7. QBASS™ 1 and QBASS™ 2 Freq.:** Use these switches, *QBASS™ 1* and *QBASS™ 2* to program the *QBASS PLUS™* circuit frequency.
- 8. Xover FULL/HP Switch:** Select the desired crossover setting FULL/HP.
- 9. Sub Sonic Adjustment:** Adjusts the crossover between 20Hz and 100Hz.
- 10. Gain:** Use this control to match the output level of the source unit to the amplifier.
- 11. Input:** Plug in the RCA leads from your source here.

12. -12dB Input Attenuation: Push this switch 'IN' for high voltage (4V-12V) capability. This button pushed 'IN' must be used for speaker level input on common ground head-units or for high voltage line drivers.

13. Phase: Adjust the phase of the output relative to the amplifier input.

14. RCA Outputs: RCA outputs provide HP/LP/FULL 30-4kHz signal to another amplifier.

DCX-500.1, 1000.1, 1500.1 END PLATE DIAGRAMS

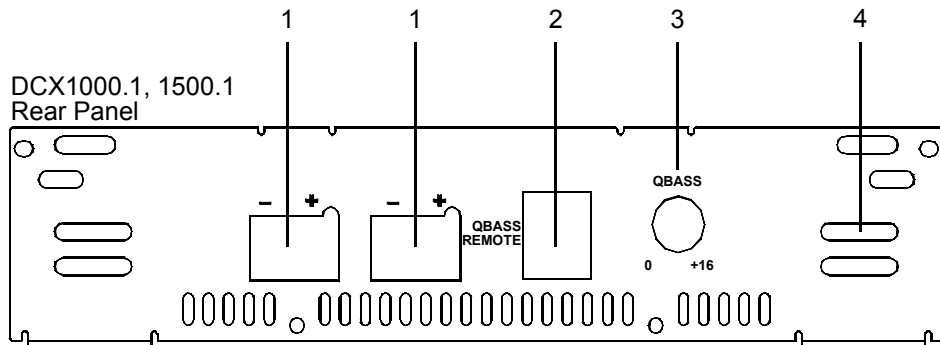
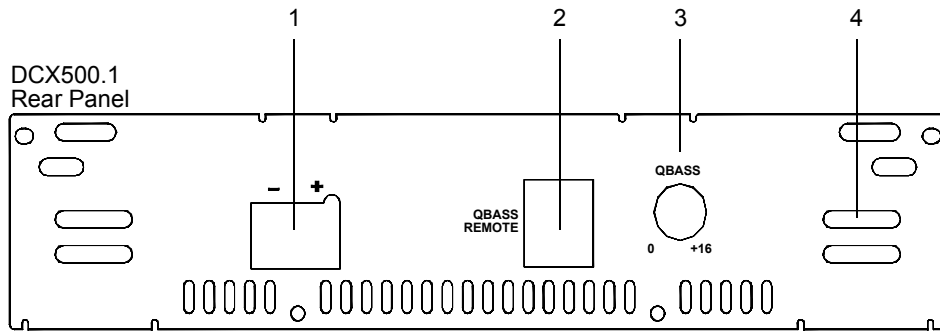

1. Power/Ground PowerLock™: After you have securely connected your power and ground wires, plug in the Power/Ground PowerLock™ connector here. Note that the DCX1000.1 and 1500.1 have two of these receptacles. You must connect the power and ground cables to both PowerLock™ terminals for optimum operation.

2. QBASS REMOTE™: Plug in the data cable from the optional QBASS REMOTE™ dash mounted level control here. (The remote level control will bypass the amplifier's on board QBASS™ control.)

3. QBASS™ Level Control: Controls bass boost, centered at 40Hz with up to 18dB of boost.

4. Cooling Plenums: Maintain a minimum 2” clearance around cooling plenums for proper amplifier cooling.

INPUTS

There are two sets of RCA jacks on the front end of your amplifier. The RCA cables from your source unit go in the set labeled INPUTS. If your source unit doesn't have RCA outputs, then add a set of RCA plugs (available at your dealer) to your front or rear set of speaker leads (see drawing below). Plug them into the input jacks, and push in the **-12dB** input attenuation switch.

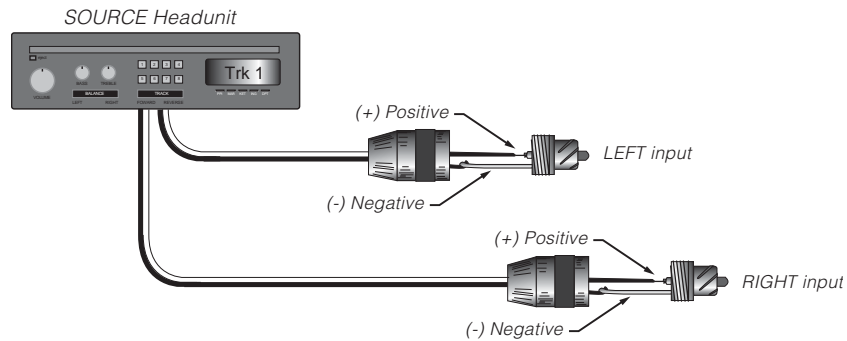

ADVANCED INSTRUMENTATION INPUT

The Advanced Instrumentation Input has been incorporated from the legendary *PrecisionPower™ 2500F1*. This circuit completely isolates the chassis ground from the audio circuit of the amplifier and reduces noise radiated into your signal cables by up to 40dB. This is equivalent to a noise reduction of approximately one hundred times what the noise level would be without this circuitry. It provides all the benefits of a true balanced line without the need of any special cables (see diagram below). This type of input works with any conventional RCA cables.

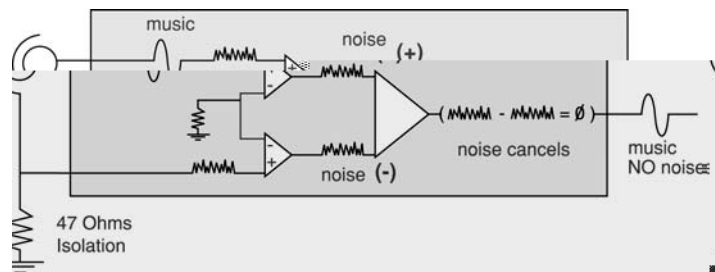

QBASS PLUS/QBASS REMOTE

On **DCX 500.1**, **DCX 1000.1**, and **DCX 1500.1** amplifiers, we've taken bass control to a higher level with **QBASS PLUS™**. The two **QBASS™** switches (labeled 1 and 2) on the front end of the amplifier allow you to select one of four frequency centers 30Hz, 36Hz, 44Hz and 60Hz. On the rear end plate you will find the **QBASS™** level control and plug-in for an optional **QBASS REMOTE™** dash mounted level control. Adjust the level control clockwise for up to +18dB of boost at your selected frequency.

QBASS™ Settings		
1	2	Freq.
IN	IN	30Hz
IN	OUT	36Hz
OUT	IN	44Hz
OUT	OUT	60Hz

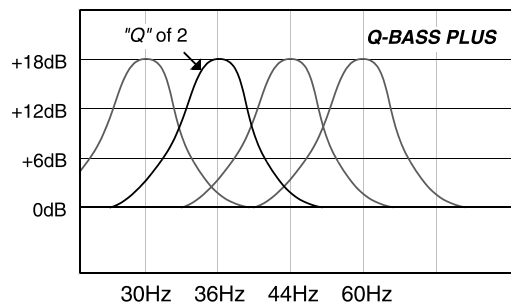

CAUTION: QBASS PLUS™ should only be used in systems with a strong subwoofer section. +18dB is a tremendous amount of bass boost and may damage your speakers or create excessive distortion if abused.

The optional **QBASS REMOTE™**: This boost control can be mounted in the dash and will supersede the boost control on the endplate.

The **PrecisionPower DCX™** amplifiers no longer need an optional **QPORT™** to connect multiple **QBASS PLUS™** equipped amplifiers while using one **QBASS REMOTE™**. The new **QBASS PLUS™** circuitry in the **DCX** amplifiers is now positioned before the crossover circuit. In doing this, **PrecisionPower™** engineers have allowed you to daisy chain your RCA output to the next amplifier input, causing the first amplifier's **QBASS REMOTE™** to become the master control amplifier. See your authorized **PrecisionPower™** dealer for more information!

TC-X CROSSOVER

Your new **DCX** amplifier has a **TC-X** Crossover (Total Control X-over®) 30Hz-4kHz (see this guide for Crossover Chart). 12dB per octave phase correlated crossover built-in to provide superior system flexibility without the added expense and installation of an outboard crossover. The speaker outputs of your amplifier are high pass, low pass, or all-pass according to the HP/LP/FULL switch on the front endplate. You would choose low pass (middle position of switch) to use this amplifier for subwoofers, choose high pass (left position of switch), or full (right position of switch) to use this amplifier for full range speakers.

The RCA outputs are controlled by a separate HP/LP/FULL switch, and are always independent of the speaker output crossover. As well as being able to independently select HP/LP/FULL, your new **DCX** amplifier allows independent selection of frequencies from 30Hz-4kHz (see Crossover Detent Chart in this guide).

DCX 500.1/1000.1/1500.1

Front - 24dB/Octave, Detented High Pass 30Hz-4kHz

Output - 12dB/Octave, Detented; HP/LP/FULL

Sub-Sonic - 12dB/Octave Detented; High Pass; 5Hz-80Hz

QBASS PLUS™ - on Front Channel - up to 18dB @ 30, 36, 44, 60Hz

CROSSOVER DETENT CHART

Detent #	Low Pass Frequency (Hz) @ -3dB	High Pass Frequency (Hz) @ -3dB
1	28	52
2	28	52
3	30	52
4	30	56
5	30	56
6	32	60
7	34	64
8	36	72
9	38	76
10	42	80
11	46	88
12	50	92
13	52	100
14	54	116
15	60	132
16	66	148
17	76	168
18	88	192
19	100	216
20	116	244
21	136	284
22	144	348
23	168	404
24	198	468
25	240	512
26	286	564
27	310	624
28	340	700
29	380	800
30	424	932
31	484	1036
32	576	1144
33	632	1300
34	748	1504
35	932	1812
36	1076	2196
37	1428	2840
38	1700	4116
39	2436	4540
40	2830	4728
41	2980	4728

ADJUSTING INPUT GAIN

1. Adjust all amplifier input gain controls to just above minimum sensitivity (fully counterclockwise).
2. Using the cleanest music source (CD) playing, turn up the head unit source volume until you can hear distortion. Now turn it down a bit until you cannot hear the distortion (usually just below full volume).
3. Increase the amplifier gain (clockwise) until the onset of audible distortion. Then decrease the gain to the point just before the distortion starts. This setting minimizes background noise and prevents overload.
4. Repeat step 3 for any remaining independently controlled amplifiers (rear and subwoofer gain controls) in the system.

HIGH MASS INTERNAL HEATSINK

The unique heatsink on your **DCX** amplifier has been designed with fins on the inside of the aluminum extrusion. This allows for the transfer of heat from the circuitry to the heatsink fins and out through the vents in the endplates. Be sure you provide ample space around the amplifier for cooling: at least 2" on all sides.

AP-IV PROTECTION CIRCUIT

Short Circuit Protection engaged: The **DCX** amplifiers will turn off and try to come back on immediately. The amplifier will cycle like this indefinitely with "blips" of sound each time. If this is the case, check your speakers and wiring for low impedance and short circuits.

Thermal Protection engaged. The **DCX** amplifiers will turn off and after a minute or so will come back on. In this case, ensure that there is nothing blocking the normal convection airflow of the amplifier. No obstruction should be within 2" of the amplifier on all sides.

Note: Low battery voltage will cause the amplifier to run warmer and possibly damage the amplifier.

TROUBLESHOOTING

NO SOUND Is the LED illuminated?

YES

NO

Check Power and Remote
turn-on wire for voltage.
Make sure the ground wire
is secure.

STILL NO SOUND

See your Authorized *PrecisionPower™* Dealer or call 1-800-62POWER.

SOUND IN ONE CHANNEL ONLY

Reverse the left and right speakers by unplugging the speaker connector,
turning it over and plugging it back in.

SOUND IS NOW IN

OPPOSITE CHANNEL

Reverse RCA inputs.

SAME CHANNEL

Problem is in the speaker or
speaker wire of the silent
channel.

SOUND IS NOW IN

OPPOSITE CHANNEL

Reverse RCA inputs
at head unit.

SAME CHANNEL

Problem is in the amplifier.
See your local Authorized
PrecisionPower Dealer or
call 1-800-62POWER.

SOUND IS NOW IN

OPPOSITE CHANNEL

Problem is in the head
unit or before the amplifier.

SAME CHANNEL

Problem is in the RCA
cables.

...RO
...on-tran
...in a manne
...the unit caused
...if the product h
...neglect, improper serv
...materials or construction. ALL W
...TO EXPRESS WARRANTY, IM
...MERCHANTABILITY, FITNESS FOR
...WARRANTY OF NON-INFRINGEMENT
...EXPRESSLY EXCLUDED TO THE MAX
...AND DIRECTED NEITHER ASSUMES N
...ASSUME FOR IT ANY LIABILITY IN COM
...PRODUCT. DIRECTED HAS ABSOLUTE
...ACTS OF THIRD PARTIES INCLUDING
...INSTALLERS. Unit must be returned
...consumer's name, telephone number, and
...address, and product description. IN OR
...VALID, YOUR UNIT MUST BE SHIPPED
...AN AUTHORIZED DIRECTED DEALER A
...FOR WARRANTY REPAIR WITHOUT
...INSTALLATION WILL BE COVERED BY
...LABOR WARRANTY. Note: This warranty
...removal and reinstallation of the unit. BY F
...CONSUMER AGREES AND CONSENTS
...CONSUMER AND Directed SHALL BE R
...CALIFORNIA LAWS IN SAN DIEGO, CALIF



Directed
ELECTRONICS, INC.